

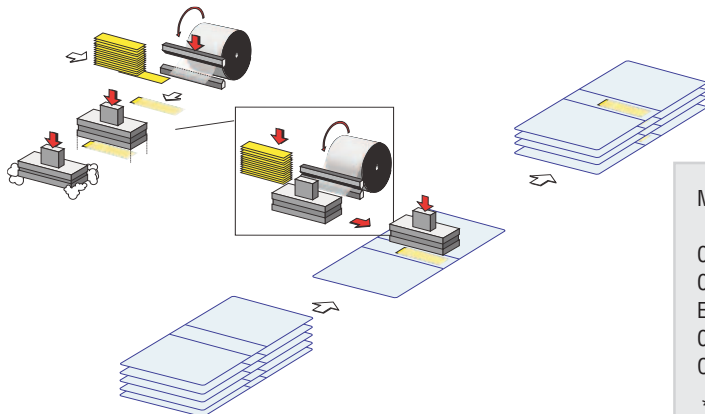

# LH 15

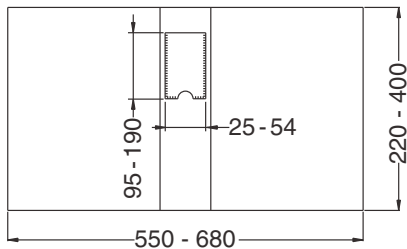

- Macchina automatica per saldare porta-etichette in plastica sul dorso di classificatori, completa di unità posa etichetta in carta
- Automatic machine to weld plastic pockets onto file spines, supplied with paper label positioning unit
- Machine automatique à souder des porte-étiquettes en plastique sur les dos des classeurs, complète d'unité pose étiquette en papier
- 配备纸张标签定位装置，焊接文件盒脊上塑料标签袋的自动化机器

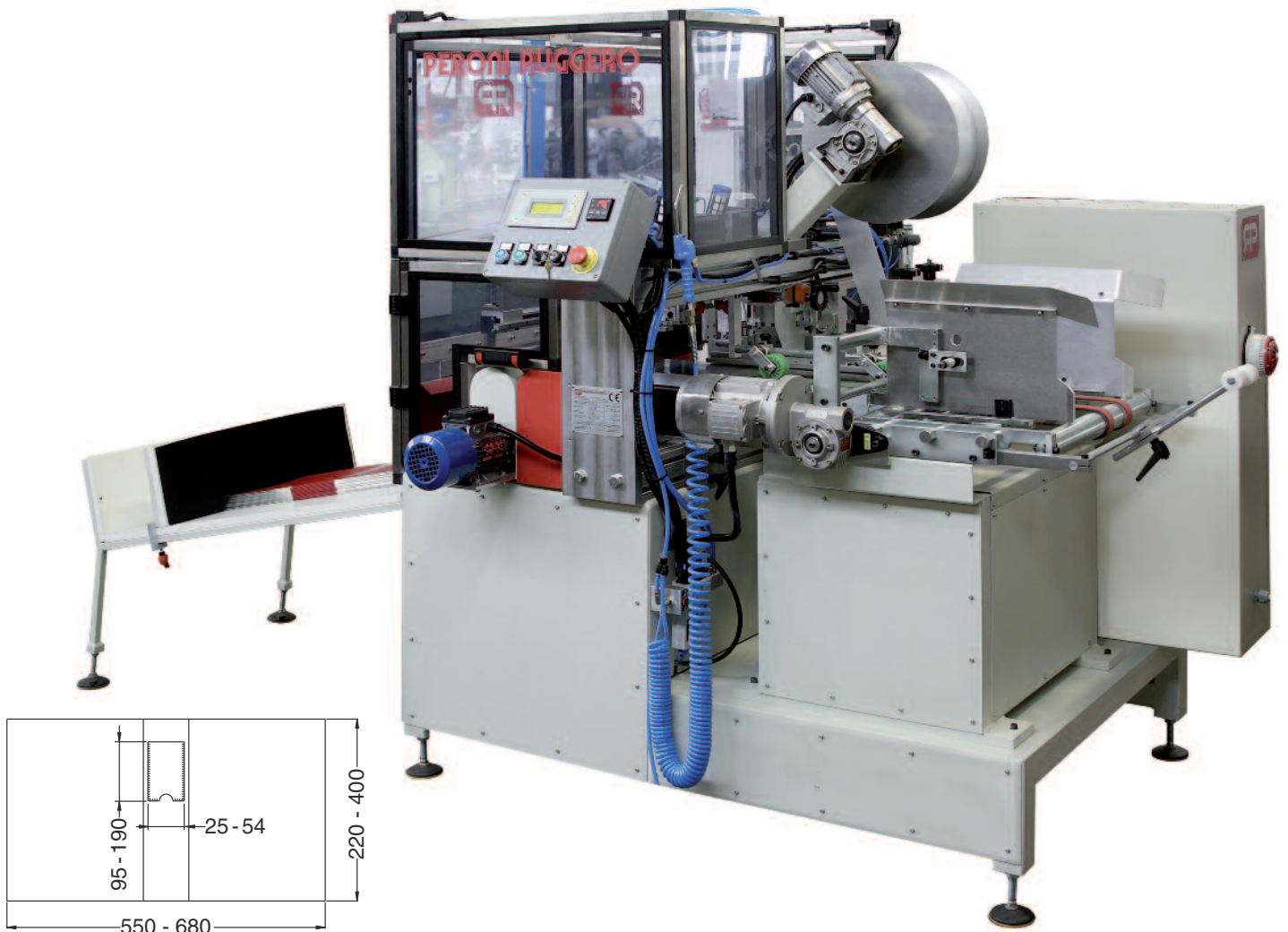

Materials:	Flat cases in polypropelene and pvc, Film spools made of pp or pvc, Paper labels
Cardboard thickness:	1 mm to 2,5 mm
Capacity:	up to 20 pieces/minute*
Electrical power req.:	2,5 Kw
Compressed air:	300 NL/min. (pressure 7 bar)
Overall dimensions:	L= 2000 mm W =1400 mm H=1800 mm

\* Production capacity of every machine depends on sizes, type of materials, glues and operator skill

Peroni's policy is one of continual product improvement and we can reserve the right to alter design and/or specifications without notice

